

EPC - FUSION BONDED EPOXY COATED CAST IRON HUBLESS BEND & CROSS TEE



COMPLY WITH EN877:2010 01

COATING CHARACTERISTIC

Fittings:

Epoxy fittings inside and outside: Fusion bonded epoxy coating.

Coating Thickness: Min- 240µm

4"X2"X90 DEG BEND

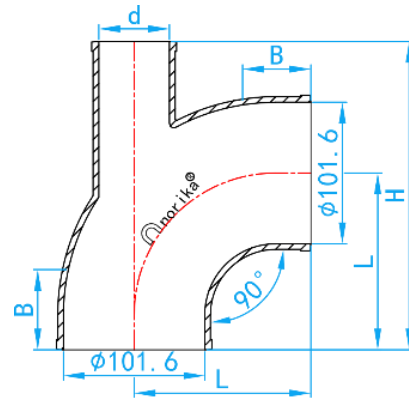
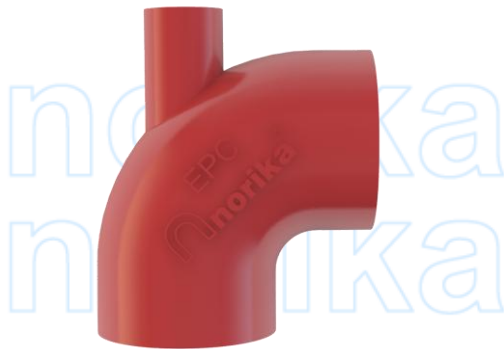

CROSS SECTIONAL VIEW

DIMENSIONS

SKU	SIZE (mm)	B (mm)	L (mm)	d (mm)	H (mm)	WEIGHT (kg)
HUBEB9010050	100X50	35	125	50.8	218	2.50

CROSS TEE 88°

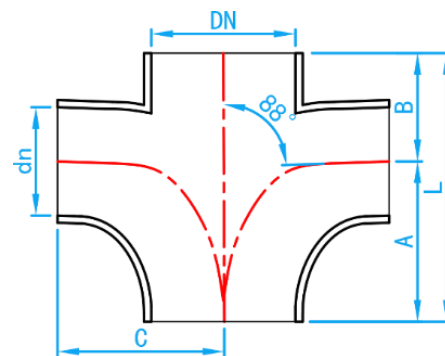

CROSS SECTIONAL VIEW

DIMENSIONS

SKU	DN (mm)	dn (mm)	A (mm)	B (mm)	L (mm)	C [mm]	WEIGHT (kg)
HUBECT10050	100	50	100	80	180	105	2.21
HUBECT100100	100	100	120	110	230	120	3.26
HUBECT150100	150	100	130	115	245	145	5.15

Notes: The tolerance for Weight is $\pm 10\%$.